



# TMX

Tubular Mixed Flow | Product Guide |



LOREN COOK COMPANY

# INTRODUCTION



With efficiency near QMX levels and a lower price point TMX offers advantages of a mixed flow with lower cost of operation.



## DESIGNED FOR

low pressure, low temperature, indoor supply/exhaust/return air applications



## PERFORMANCE RANGE

410–24,400 CFM



## STATIC PRESSURES

up to 3" w.g.

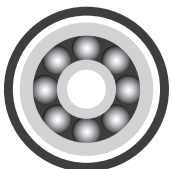

## BEARING LIFE

L10 200K Sizes 90-180  
L10 100K Sizes 202-330



## EQUIPPED WITH

the Cook Contour® axial-centrifugal hybrid impeller



## REDUCED

cost of ownership



## OFFERED IN 12 SIZES

ranging from 90 to 330



## SIZES 90 - 135

arrangement 4 exclusively use Cook Vari-flow® EC motors

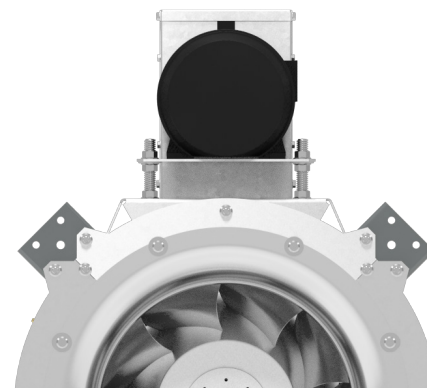

## EXTRA BENEFITS

- ▶ Efficiency near QMX levels
- ▶ UL/cUL 705 Listing is standard on all TMX models.
- ▶ Lower initial cost than other mixed flow fans.
- ▶ Lighter weight than other mixed flow fans
- ▶ Available with Vari-Flow® motors and controls.



**For more information, look at the Vari-Flow® Product Guide or contact Loren Cook Company at 417-869-6474.**



# MIXED-FLOW ADVANTAGES



The Cook Contour® mixed-flow wheel produces a highly efficient, quiet and compact tubular inline fan. Proper airflow is crucial for high fan efficiency. Let's see how it works.

These illustrations show cross sections of typical mixed-flow, tubular centrifugal and axial fans. Flow lines developed with CFD software and added to the illustrations show the different air patterns between each type of fan. Areas in red indicate high turbulence zones that result in loss of efficiency and excess noise.

## MIXED-FLOW

## AXIAL

## CENTRIFUGAL

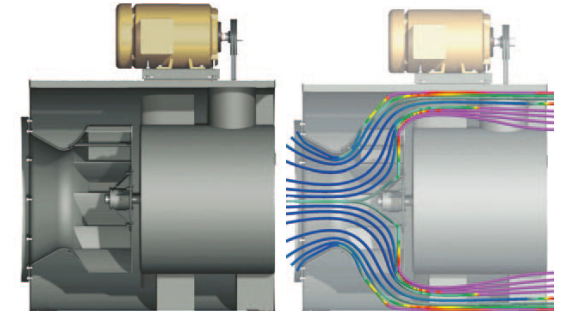
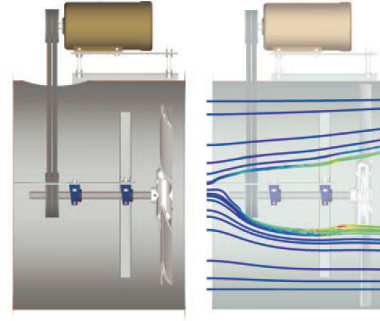
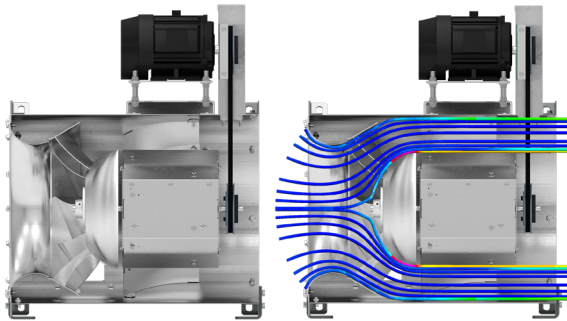

- ▶ Two gentle changes in airflow direction
- ▶ Lower RPM required for equal flow and pressure
- ▶ Highest static efficiency of inline fans
- ▶ Smallest diameter with equal performance
- ▶ Lowest sound levels of equal size units
- ▶ Large inlet opening yields low inlet velocities
- ▶ Design allows for close wall proximities when used in built-up air handlers.

- ▶ Airflow straight through with no direction changes
- ▶ High airflow volume in a relatively small diameter
- ▶ May require inlet bell and outlet cone
- ▶ Less efficient at high pressures

- ▶ Two abrupt 90° changes in airflow directions
- ▶ High pressure capability
- ▶ Higher RPM required for equal flow and pressure
- ▶ Larger size required for equal performance

# TMX ADVANTAGES



Efficient, quiet inline fan for indoor, clean air, low pressure applications

The QMX has been the dominant mixed flow fan on the market for years, with the industry's highest efficiency, low sound and a compact size. Some systems don't require the robust construction of the QMX. This is where the TMX comes in. The TMX offers the advantages of a mixed flow fan at a lower price range.

## MODEL COMPARISON

The TMX is more efficient than a square or tubular inline centrifugal and more economical than the QMX. The TMX is an excellent choice for indoor, clean air and low pressure fan applications.

This brief comparison will help understand where the TMX fits in:

Model	TMX	QMX	SQN	TCN
<b>Sizes</b>	12	18	18	20
<b>Size Range</b>	90-330	90-600	60-402	60-490
<b>Max CFM</b>	24,400	119,500	26,000	52,000
<b>Max SP (in wg)</b>	3"	9"	1.25"	5"
<b>Max Temp (°F)</b>	180	180/500*	180/200*	180/300*

\*180°F is standard construction. Upgrades are required to achieve higher temperatures.

## OWNERSHIP COMPARISON

Efficiency, reliability and initial cost all play an important role in the overall cost of owning a piece of equipment. The comparison shown below gives an indication of the cost of ownership of different types of inline fans over the course of 5 years. These fans are all size 245 operating year-round, 12 hours a day, 5 days a week with an electricity cost of \$0.11 per kWh. The TMX offers excellent performance paired with an economical cost of ownership.

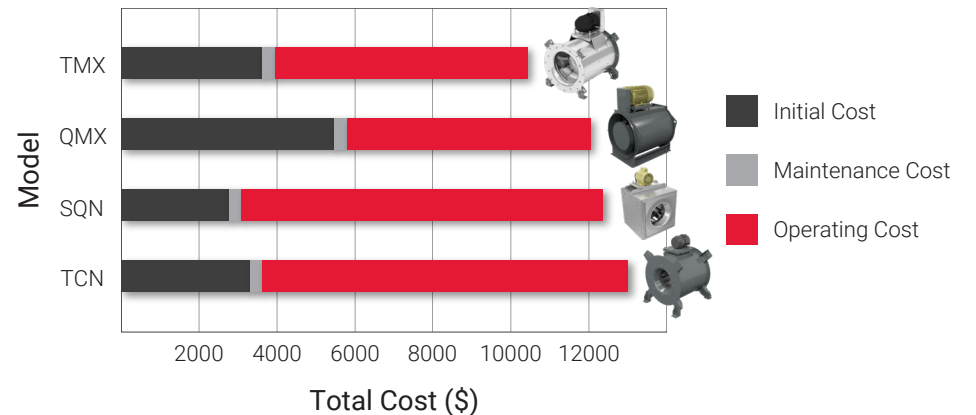

# STANDARD CONSTRUCTION



The standard construction features are shown below on the TMX Arrangement 9.

## INLET VIEW

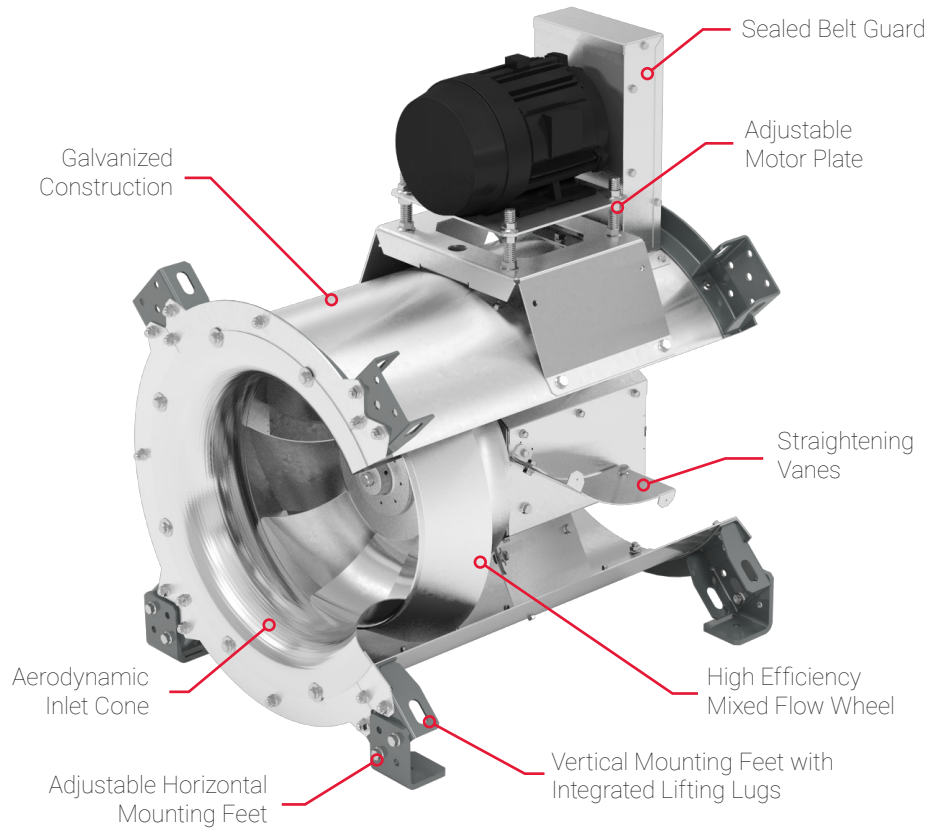

## OUTLET VIEW

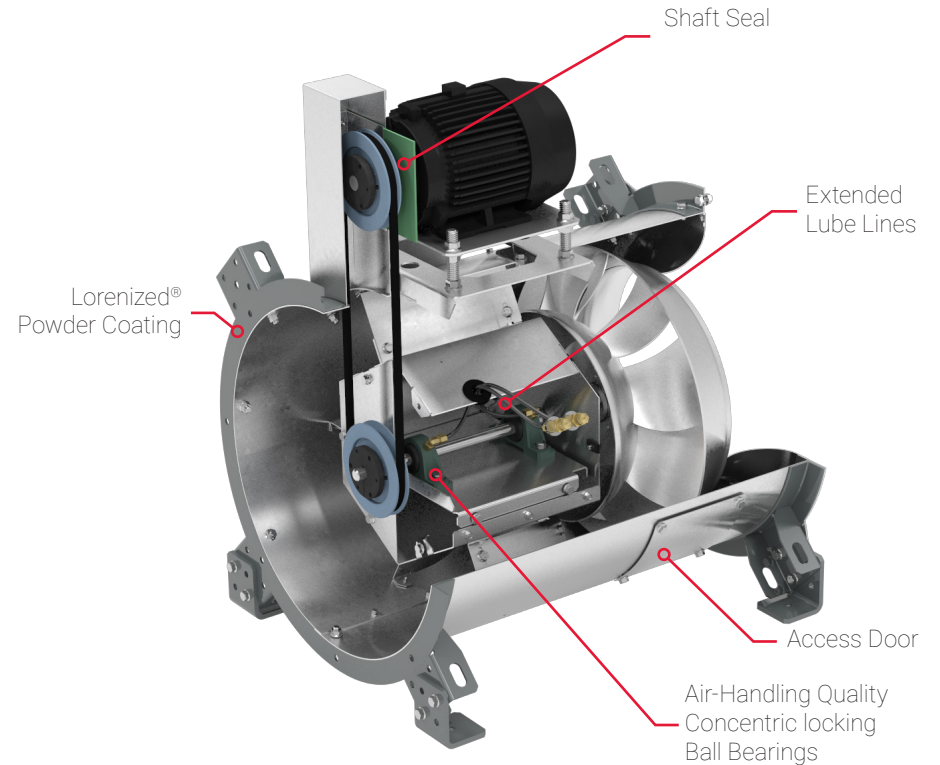

# STANDARD CONSTRUCTION



The standard construction features are shown below on the TMX Arrangement 4.

## INLET VIEW

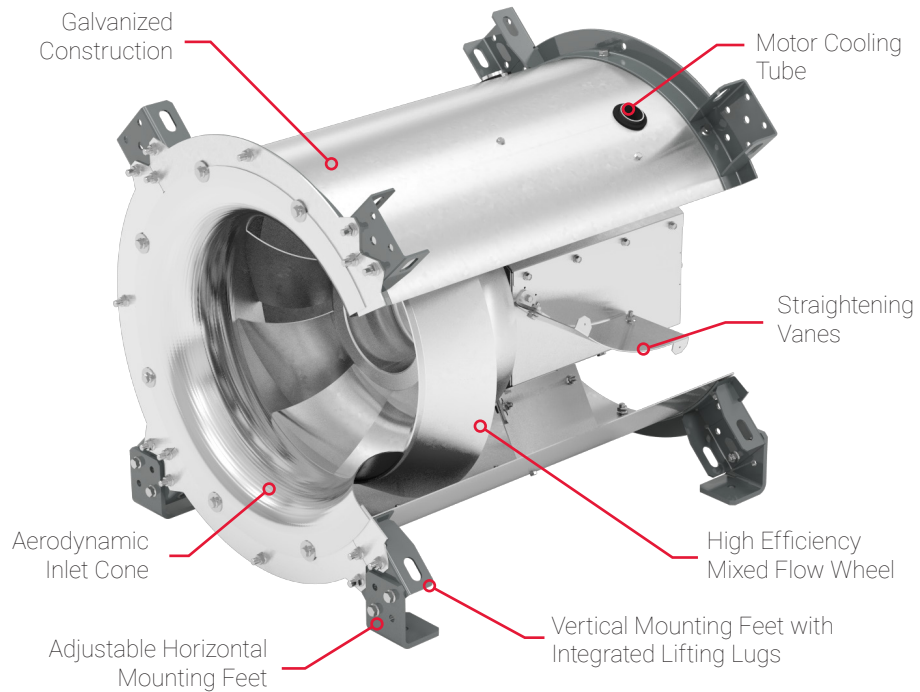

## OUTLET VIEW

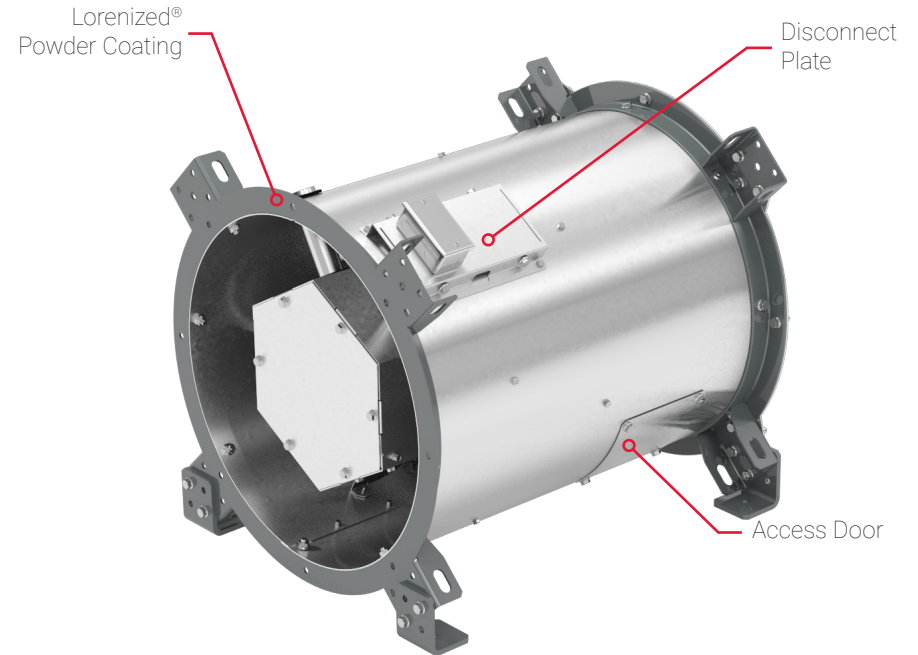

# TMX ACCESSORIES



Beyond the TMX Standard Construction Features, Cook offers accessories to fit your custom air-movement requirements and/or preferences.

## ARRANGEMENT 9

Details on next page.

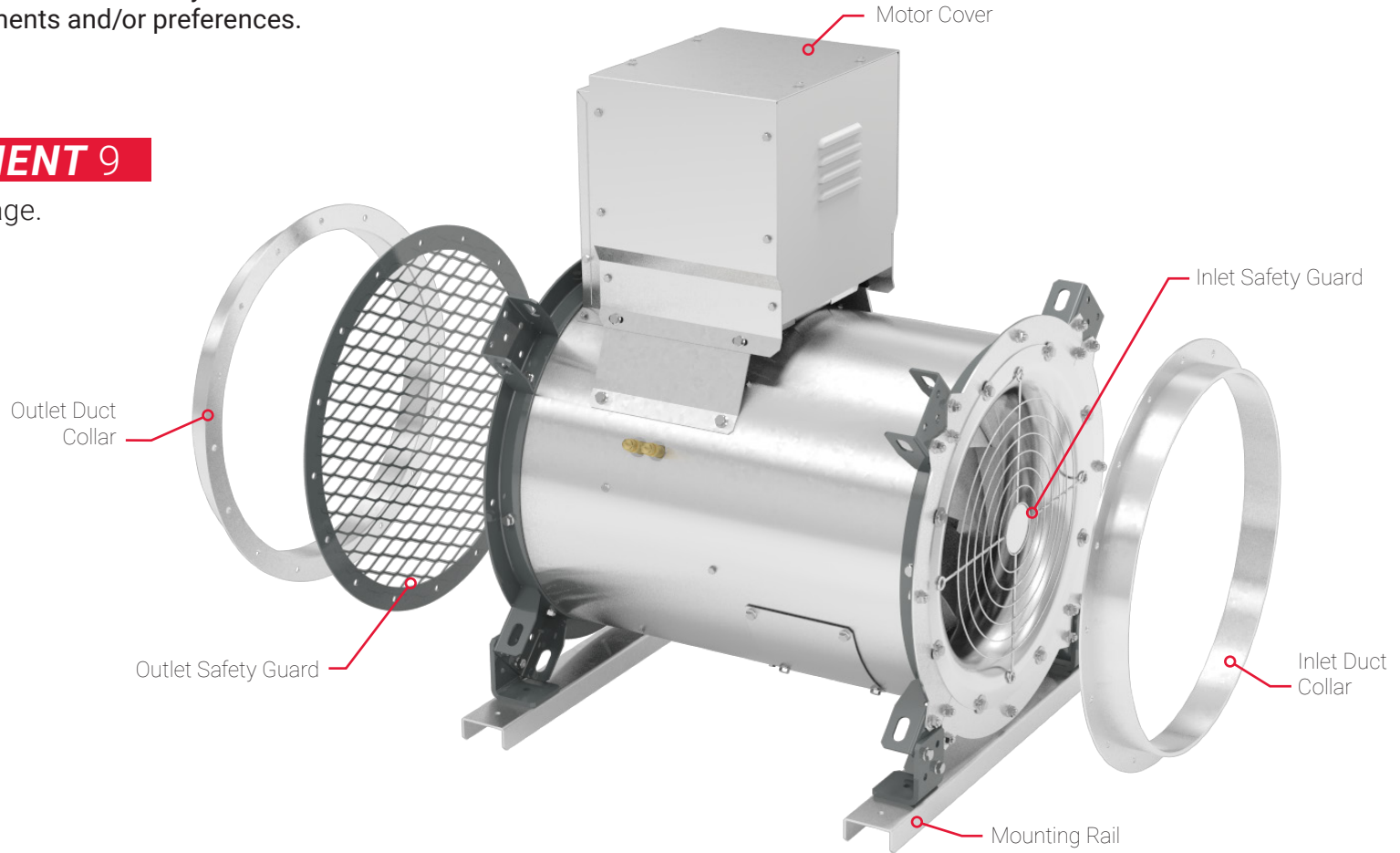

# ACCESSORIES EXPLAINED



Beyond the TMX Standard Construction Features, Cook offers accessories to fit your custom air-movement requirements and/or preferences.

## INLET/OUTLET DUCT COLLAR

- ▶ Galvanized inlet/outlet duct collar make installing slip on connections easy

## INLET/OUTLET SAFETY GUARDS

- ▶ Inlet/Outlet safety guards protect personnel and prevent debris from entering the fan
- ▶ Safety guards are constructed of either expanded metal or wound spiral rings and are factory installed

## MOTOR COVER

- ▶ The motor cover encloses the motor and shields the motor from dirt, dust, moisture and other contaminants. Arrangement 9 only

## MOUNTING RAILS/BASE

- ▶ Mounting rails/base are available for applications where the motor center of gravity is offset with respect to the fan center of gravity

Accessory not pictured.

## FLEXIBLE DUCT CONNECTOR

- ▶ The flexible duct connector provides a flexible connection between the fan and the attached ductwork. The connector is constructed of reinforced neoprene fabric and aluminum bands

## EXTERNAL IVD

- ▶ An external inlet vane damper, IVD, is used to provide precise air volume control while maintaining maximum efficiency and stable operation at reduced load conditions



# TMX ISOLATORS



Cook offers five types of isolators which reduce vibration transmission from equipment to building structure.

## FLOOR MOUNTED

Rubber-in-Shear



Free Standing Spring



Restrained Spring

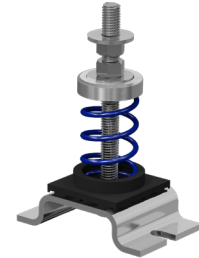

## CEILING MOUNTED

Rubber-in-Shear

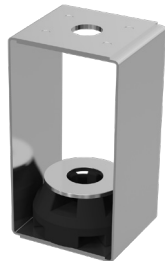

Spring



# INSTALLATION & MOUNTING



Recommended horizontal installation and mounting are shown here for various motor positions. Additional details can be found in the TMX Installation, Operation and Maintenance Manual.

## CEILING

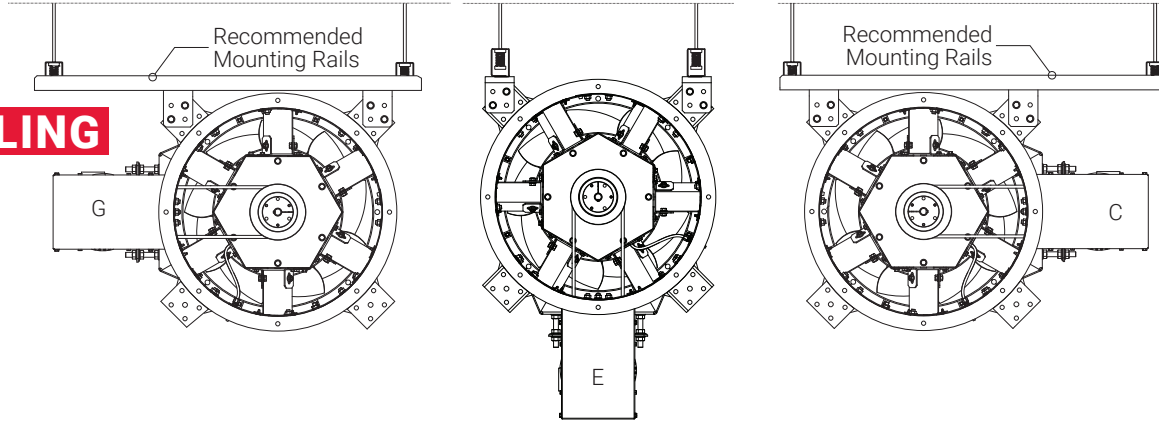

## FLOOR

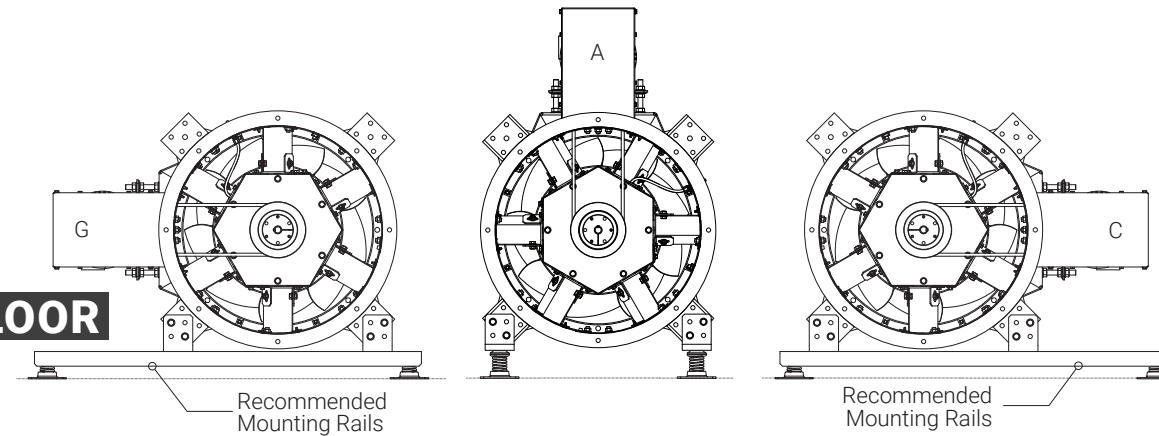

## DESIGN BENEFITS



Horizontal mounting configurations are provided with a standard support for both ceiling and floor applications.



The mounting configurations and the motor position can be changed in the field.



Lifting lugs are provided to assist in product installation.



Mounting rails are recommended for horizontal configurations with motor positions C and G with vibration isolation.



Motor position is determined by viewing fan outlet.

# INSTALLATION & MOUNTING



Recommended vertical installation and mounting. Additional details can be found in the TMX Installation, Operation and Maintenance Manual.

## CEILING

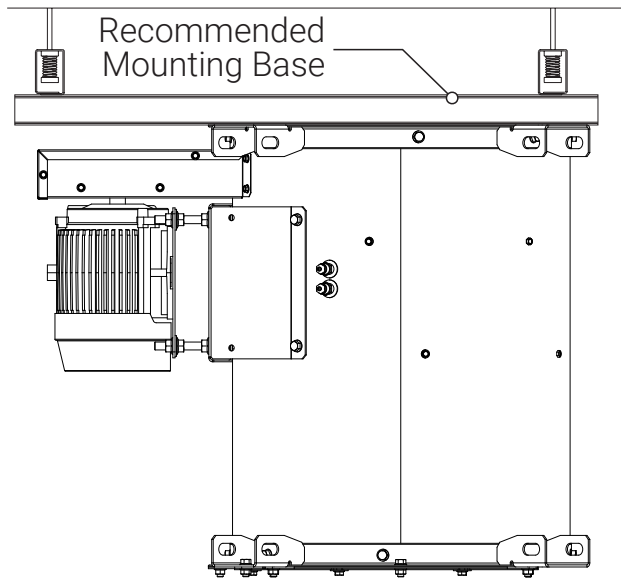

## FLOOR

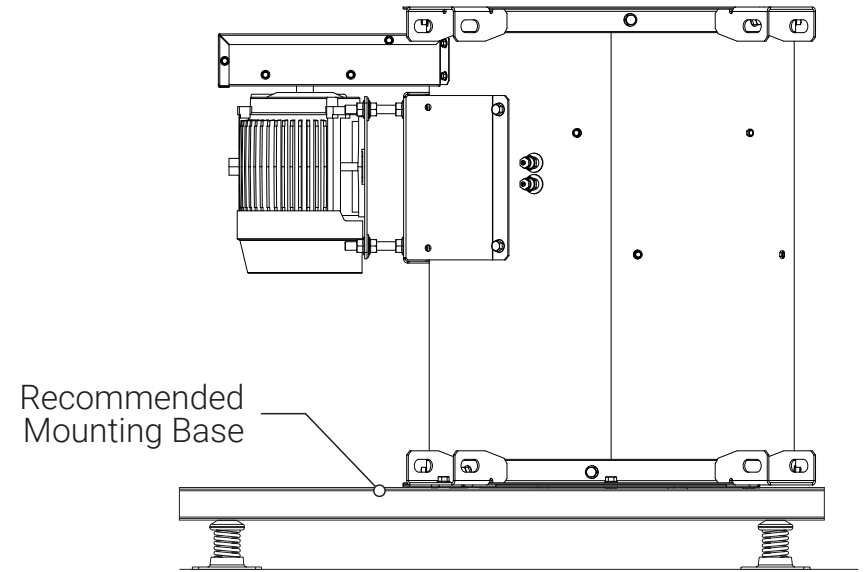

## DESIGN BENEFITS

- ▶ Vertical mounting configurations are provided with four mounting brackets welded to each end.
- ▶ The brackets allow a unit to be installed in either ceiling or floor configuration in both upblast and downblast applications.
- ▶ A mounting base is suggested for any vertical installation with vibration isolation.

# OPTIONAL COATING



The TMX is available with **Lorenized™** coating. The Lorenized coating in gray is standard. It is also available in 12 other colors shown.

## LORENIZED COATING

- ▶ Electrostatically applied, baked polyester powder coating
- ▶ Undergoes a five-stage environmentally friendly pretreatment/wash process before coating
- ▶ Baked and cured at 400°F; final coating thickness of 1.5–2.5 mil
- ▶ Coating is required to exceed 1,000 hour salt spray under ASTM B117 test method
- ▶ Offers strong chemical resistance, durable mechanical performance and tough protection from outdoor elements

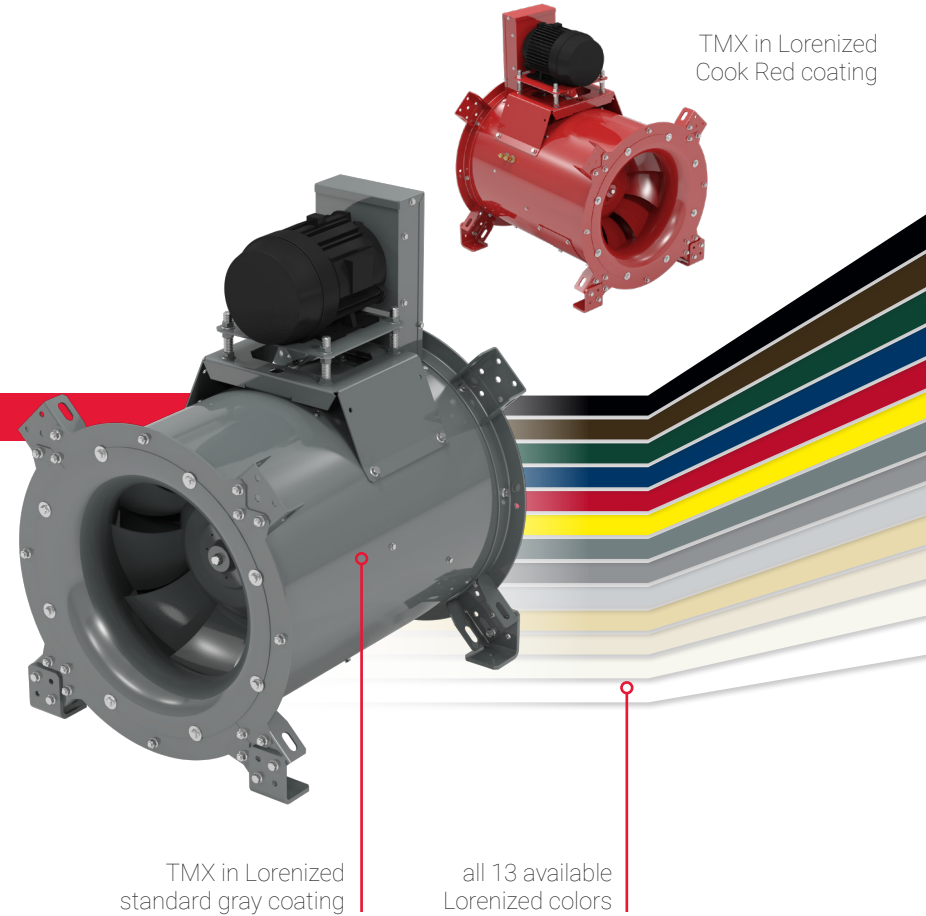

 **See our Coatings Brochure for more information.**

# TMX CERTIFICATIONS



Through professional third party companies, the following information explains which products have obtained and maintained the title of "certified" here at Loren Cook Company.

## AMCA SOUND AND AIR

### **AMCA Certified Ratings Seal**

Loren Cook products that bear the AMCA Certified Ratings Seal are licensed by AMCA International. All TMX models meet the AMCA Standard and are within the product scope of AMCA International.



## UL 705 LISTED

### **Power Ventilator**

The UL 705 Listing is the standard for electrical safety for permanently connected power ventilators. All TMX models are constructed in accordance with UL 705, only when with motors.



# OVERALL DIMENSIONS



The following overall dimensions are in inches. For more detailed dimensions, see the product submittal.

## ARRANGEMENT 9

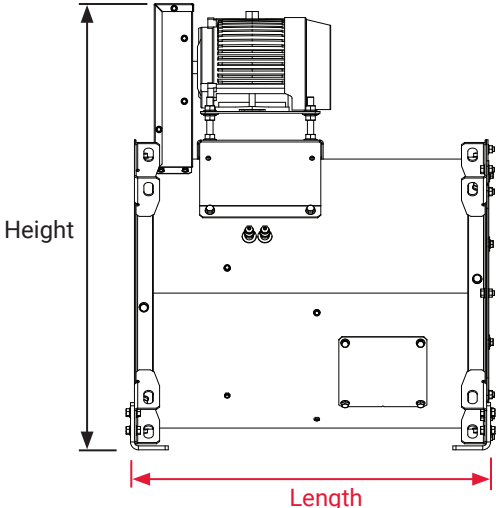
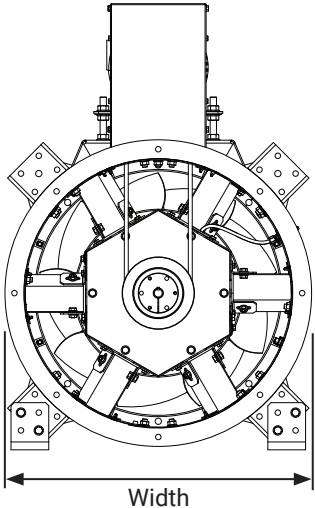

Unit Size	90	120	135	150	165	180	202	225	245	270	300	330
<b>Height</b>	29 1/16	33 3/4	35 1/2	37 5/16	39 1/2	43 5/8	46 11/16	49 15/16	57 1/16	60 1/16	63 11/16	67 3/8
<b>Length</b>	18 1/2	24 11/16	27 3/4	28	30 13/16	33 5/8	37 11/16	42	44 1/2	49 1/16	54 1/2	59 15/16
<b>Width</b>	17 3/4	20 7/8	22 7/16	24 3/8	26 1/2	28 5/8	31 3/4	34 15/16	38 3/4	42 5/16	46 1/2	50 3/4

# OVERALL DIMENSIONS



The following overall dimensions are in inches. For more detailed dimensions, see the product submittal.

## ARRANGEMENT 4

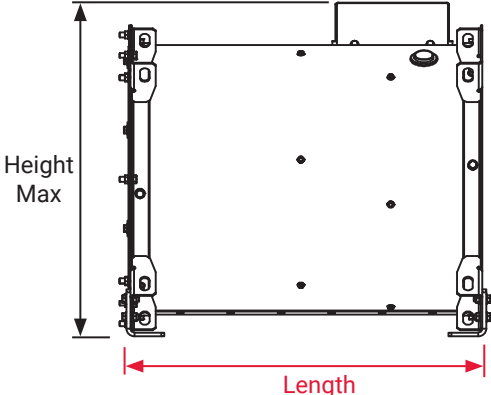
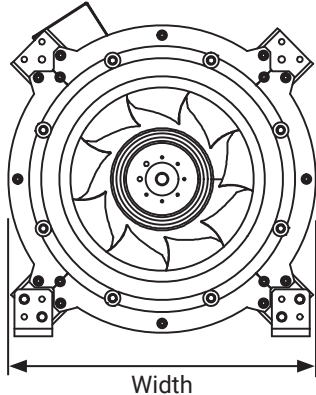

Unit Size	90	120	135	150	165	180	202	225	245
Height	18 1/4	22 1/2	24 1/2	26 1/2	28 1/2	28 15/16	32	35 3/16	40 13/16
Length	14 15/16	19 11/16	22 7/8	22 7/8	29 1/4	31 5/8	35 1/16	38 11/16	41 7/16
Width	17 3/4	20 7/8	22 7/16	24 3/8	26 1/2	28 5/8	31 3/4	34 15/16	38 3/4

