

# Energy Recovery Ventilators Models ERM, MiniVent, ERV and ERVe Preconditioners



Greenheck offers a complete line of energy recovery ventilators to reduce your building's tempering loads in all climates. From outdoor roof-mounted applications to indoor ceiling-mounted units, Greenheck's preconditioners offer the installation flexibility for both new construction and retrofit applications.

Models MiniVent, ERV and ERVe incorporate innovative design features with varying levels of configurable options and energy wheel performances to provide a quality constructed unit with operational flexibility. The result is a product that will fit seamlessly into your building to improve your indoor air quality while reducing energy costs.



Model MiniVent



Model ERV



Model ERVe

Features	Benefits
<p><b>Industry Leading Selection Software (CAPS®)</b></p>	<p>CAPS®, Greenheck's computer-aided product selection software, analyzes system design parameters quickly and provides a list of units with energy core and fan combinations. This reduces design time, minimizes cost and optimizes performance. The program outputs fan, electrical, and energy wheel performance data, as well as configuration-specific 2D and 3D drawings for easy implementation into building schedules and plans.</p>
<p><b>Compliance with Industry Standards</b></p>	<p>Code officials recognize the benefits of utilizing energy recovery in applications with large amounts of ventilation air. Greenheck's third party certification for energy wheel performance (AHRI) verifies the units provide the mandated energy recovery effectiveness per ASHRAE standards and energy codes.</p>
<p><b>Maintenance and Serviceability</b></p>	<p>Greenheck's preconditioners have been designed to allow easy access to filters, blower assemblies and wheel cassettes. As reassurance to the customer, each unit carries a one year warranty and each energy wheel (segments, cassette, belt and pulleys) carries a five year warranty.</p>
<p><b>System Efficiency and Payback</b></p>	<p>The incorporation of energy recovery allows for equipment downsizing as well as continued lower energy costs throughout the life of the equipment. This downsizing moderates the variability of loads on the system, increasing the efficiency of furnaces, electric heaters, DX coils and water systems.</p>

## Product Certifications

Greenheck takes pride in offering a high quality, reliable product. We invest our resources into designing, testing and manufacturing products to ensure customer satisfaction.



ETL Listed for electrical and overall unit safety. Every unit is tested at the factory before it is shipped to the jobsite.



Energy recovery wheels are certified by the AHRI Air-to-Air Energy Recovery Ventilation Equipment Certification Program in accordance with AHRI Standard 1060. Actual performance in packaged equipment may vary. Certified ratings are available in the Certified Product Directory at [ahrirectory.org](http://ahrirectory.org).

## How does energy recovery work?

Energy recovery is the process through which energy is transferred between the conditioned return air from the space and the fresh outdoor air which imposes the load on mechanical equipment.

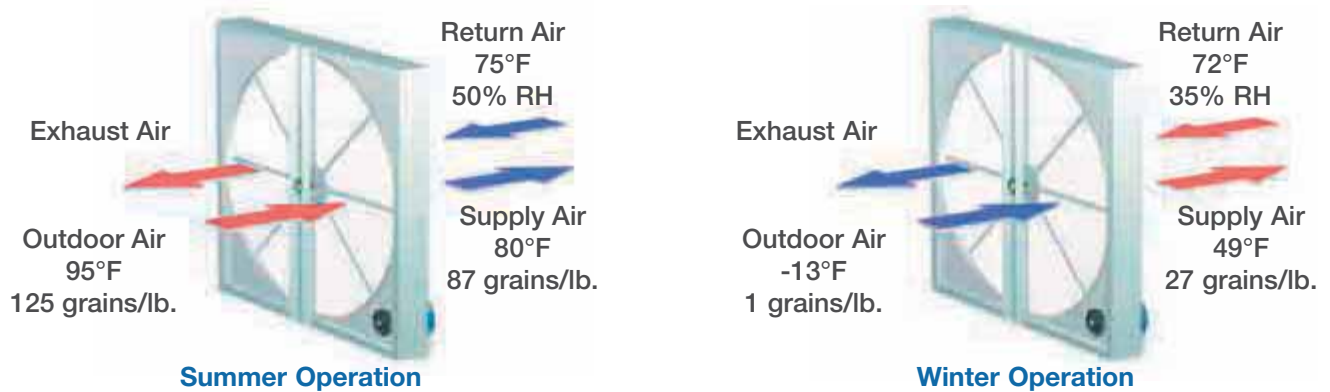

## Energy Wheel Technology

The total energy wheel is constructed of a polymer heat transfer media for sensible energy transfer and a silica gel desiccant that is permanently bonded to the polymer media for latent energy transfer. Total energy wheels are the most efficient energy recovery devices currently available in the market. When supply and exhaust airflows are balanced, energy wheels have an enthalpy recovery ratio of up to 80%. Energy wheels will have a life expectancy up to 20 years and can easily be maintained through washable, removable segments.

Performance and Construction Features	
Media	Polymer
Desiccant Type	Silica gel
Energy Transfer	Sensible and Latent
Enthalpy Recovery Ratio (ERR)	70-80%
Benefits	Highest ERR
	3-5% Exhaust Air Transfer Ratio (EATR)
	Washable
	Segmented construction
	Thin profile

## ASHRAE 90.1 Compliance

ASHRAE 90.1-2016 (Table 6.5.6.1) requires the use of energy recovery based upon a unit’s supply airflow, outdoor air percentage, geographic location and application operating hours. The standard mandates that the ERR be a minimum of 50%. This language was adopted in the 2018 International Energy Conservation Code (IECC).

The effectiveness of an energy recovery device will vary based on the type, material, and supply/exhaust airflows. This value is determined based on a test procedure outlined in the Air Conditioning, Heating, and Refrigeration Institution (AHRI) Standard 1060. All Greenheck energy wheels are third party certified to AHRI 1060.

## Typical Applications for Energy Recovery

- Animal Shelters
- Churches
- Locker Rooms
- Bars and Clubs
- Dormitories
- Nursing Homes
- Veterinary Hospitals
- Function Halls
- Schools
- Office Buildings
- Printing Shops
- Restaurants

## Energy Recovery with Ducted Air Handlers

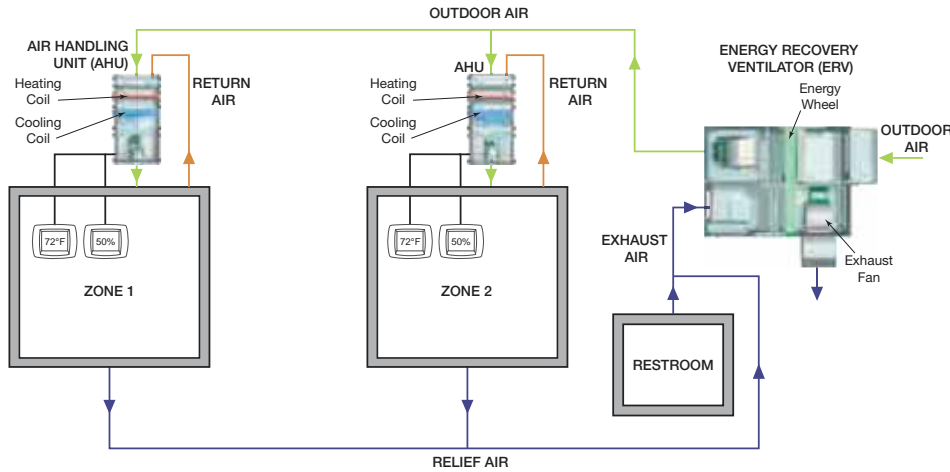

### Preconditioner Applications

These diagrams illustrate how energy recovery units can be used in conjunction with other HVAC equipment. Fresh, outdoor air enters the energy recovery unit and is pretreated before entering the heating and cooling equipment.

Whether ducting into terminal units, such as air handlers, or directly feeding into a rooftop unit, these preconditioners provide the ability to reduce the outdoor air load of these systems.

## Energy Recovery with Packaged Rooftop Equipment

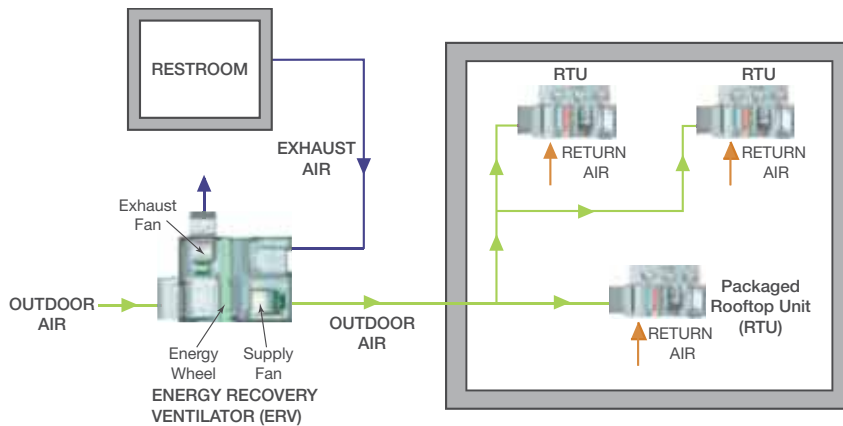

### Recovering Restroom Exhaust

ASHRAE Standard 62.1 dictates that energy recovery devices rated for less than 10% cross-contamination can return restroom exhaust through the device. Any volume of air transferred through the device can be reclassified as fresh outdoor air. All of Greenheck's energy recovery units are rated well below the 10% limit, therefore it is not only allowable to return restroom exhaust, but is recommended to maximize the benefit.

## Energy Recovery with Variable Air Volume

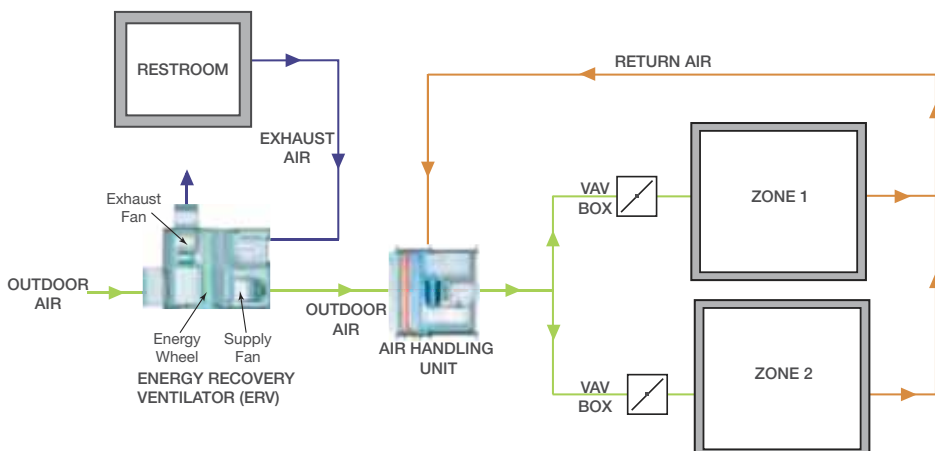

Required Supply Air (cfm)	Minimum Outdoor Air (cfm)	Minimum Exhaust (cfm)	Outdoor Design (DB/WB)	Indoor Design (DB/RH)
6,000	3,000	1,500	95°F/78°F	75°F/50%RH

## Traditional System:

An air handling unit and exhaust fan handle the entire load.

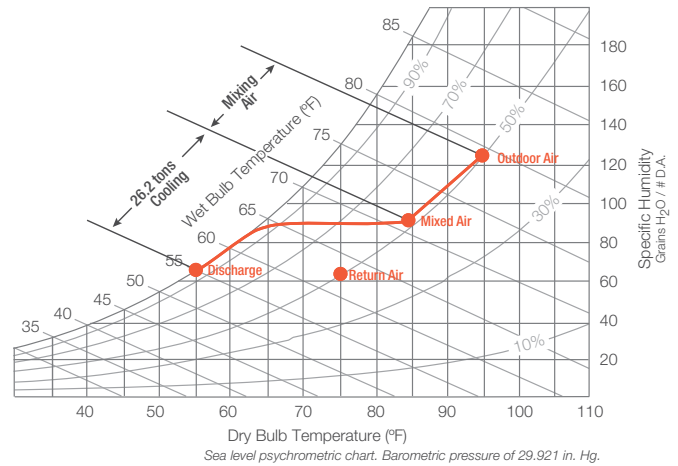
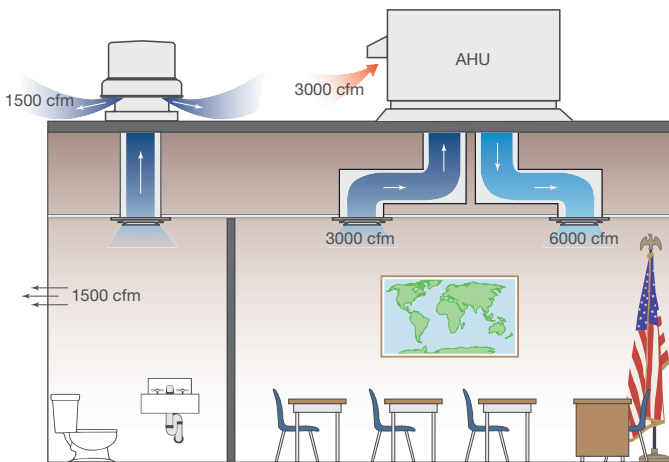

## Traditional System with Energy Recovery:

An energy recovery unit reduces the outdoor air load on the AHU and replaces the exhaust fan.

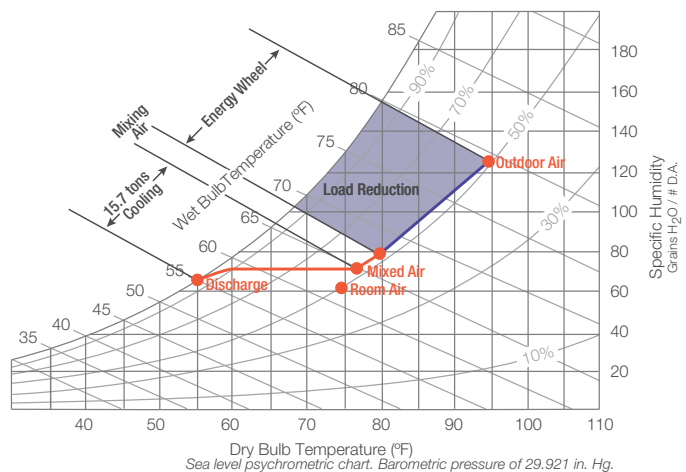
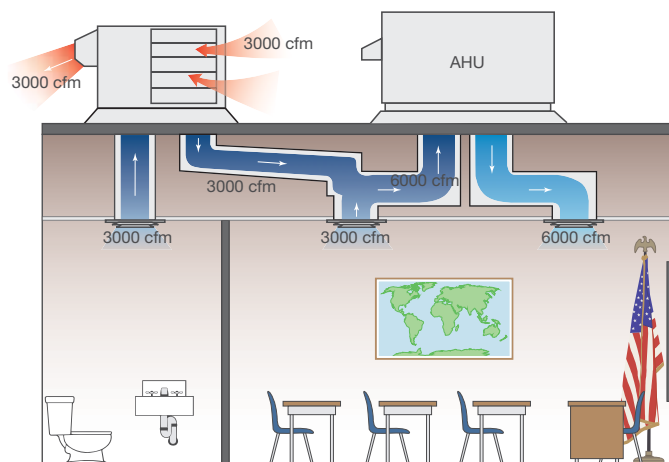

Equipment Reduction using Energy Recovery on 3,000 cfm Outdoor Air

	Natural Gas Price (\$/therm)	Electric Cost (\$/kWh)	Cooling Equipment Reduction (tons)	Annual Summer Cooling Savings	Annual Winter Heating Savings	Approximate Payback (Years)
Boston, MA	1.14	0.1433	6.29	\$451	\$1,241	1.97
Houston, TX	0.69	0.0883	11.70	\$1,584	\$308	1.19
Minneapolis, MN	0.73	0.0863	8.05	\$348	\$1,215	1.67
Phoenix, AZ	0.98	0.0950	7.12	\$531	\$374	2.04
Raleigh, NC	0.94	0.0813	10.30	\$806	\$805	1.36
St. Louis, MO	0.98	0.0804	13.53	\$625	\$1,288	1.05
Tampa, FL	1.09	0.0985	13.18	\$2,182	\$238	1.03

Actual savings will vary based on system design and application.

Data source: U.S. Energy Information Administration, *Natural Gas Annual and Monthly Electric Sales and Revenue Report with State Distributions Report, 2011*  
 Assumptions: \$4/cfm energy recovery cost; \$700/ton avoided cooling equipment cost; 70% effective energy wheel; operating hours: Mon.-Fri., 6am-6pm



Greenheck's model ERM is a modular energy recovery device capable of handling 600 to 10,000 cfm of ventilation air. This indoor unit is designed for new construction or retrofit applications where an energy recovery ventilator may not meet space requirements. The ERM consists of a fully insulated cabinet, installed as a permanent part of the duct system. The energy recovery wheel is completely accessible through a removable panel or duct access. A wiring box for connection to the electrical supply is also a standard feature.

Model	A	B	C	D	E	F	G	Approx. Weight (lbs.)	Airflow Range (cfm)	Voltage	Hertz	Amps	Phase	Motor HP
ERM-36S/H	34.3	45.4	42	14.8	14.8	14.6	16.6	170	600 - 2,300	200-230/460	50/60	1.2	1	1/6
ERM-52S/H	50.4	61.6	58.4	22.4	22.4	14.6	16.6	280	2,300 - 4,500	200-230/460	50/60	2.8	1	1/2
ERM-58H	54	64.6	62.7	24.1	24.1	16.5	18.7	440	4,500 - 6,000	200-230/460	60	1.3-1.2/0.6	3	1/4
ERM-64H	59.8	70.4	68.2	26.9	26.9	19.1	21.1	700	6,000 - 7,500	200-230/460	60	1.3-1.2/0.6	3	1/4
ERM-74H	69.9	80.2	78.5	31.5	31.5	20.1	22.1	870	7,500 - 10,000	200-230/460	60	1.3-1.2/0.6	3	1/4

All dimensions shown in inches.

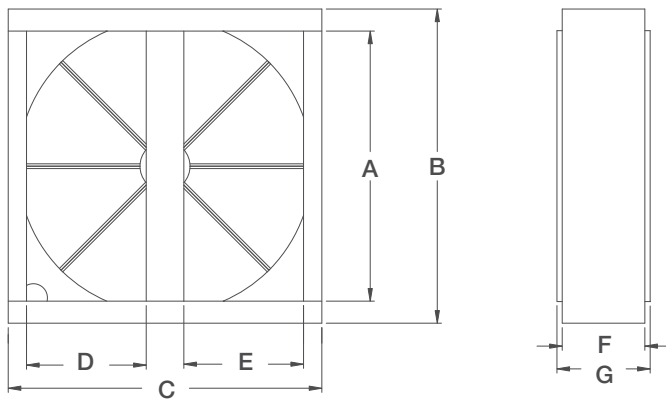

**Model Number Code**

**ERM - 36S - 15**

<p>Model Parent</p> <p>Wheel Diameter</p> <p>36 (36 in.)</p> <p>52 (52 in.)</p> <p>58 (58 in.)</p> <p>64 (64 in.)</p> <p>74 (74 in.)</p>	<p>Wheel Thickness</p> <p>15 (1½ in.)</p> <p>30 (3 in.)</p>	<p>Airflow Rate</p> <p>H - High</p> <p>S - Low</p>
--	---	--

## Typical Installation

Models ERM-36 and 52 are easily installed either vertically or horizontally. Models ERM-58, 64, and 74 must be installed in the vertical position due to size and weight. The diagram illustrates a typical horizontal installation of multiple modules where airflow exceeds single wheel capacities.

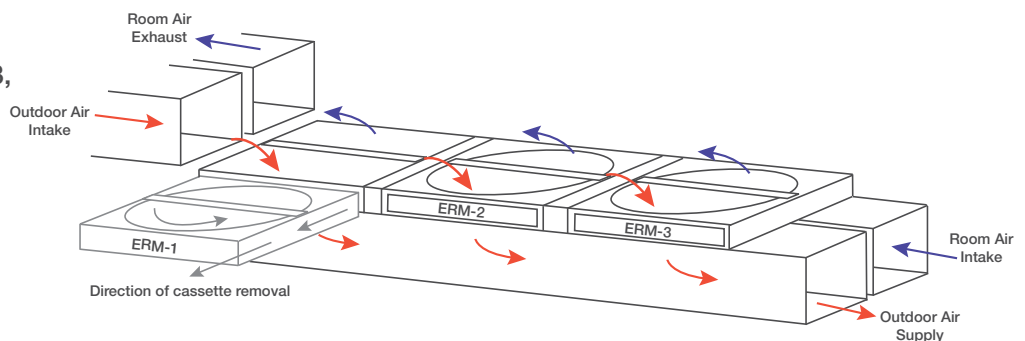

Models MiniVent-450 and MiniVent-750 are energy recovery ventilators for commercial and institutional applications that require 150 to 850 cfm of ventilation air. The compact design provides an economical solution for individual spaces, such as school classrooms and small offices. The MiniVent is designed for indoor installations and may be floor-mounted or ceiling-hung. A removable panel enables easy access to filters and enthalpy wheel. Units come standard with backdraft dampers and Vari-Green® electronically commutated (EC) motors.



Model	A	B	C	Approx. Weight (lbs.)	Airflow Range (cfm)
MiniVent-450	40.2	28.6	19.9	150	150 - 500
MiniVent-750	45.8	35.2	23.8	250	450 - 850

All dimensions shown in inches.

Available Intake/Discharge Positions				
Option	Bottom	Top	Side	End
OA Intake		X		X
SA Discharge				X
RA Intake	X			X
EA Discharge				X

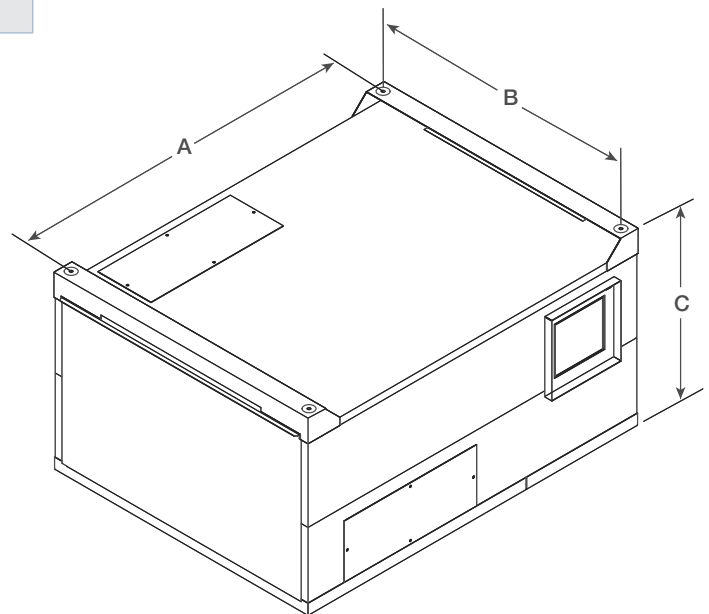

**Model Number Code**

**MiniVent - 750 - VG**

Model Parent

Nominal Airflow

450 (450 cfm)

750 (750 cfm)

Vari-Green®

## Optional Control Sequences and Product Features

### Energy Wheel Frost Control

The frost control prevents frost buildup on the energy wheel in climates that have cold outdoor winter temperatures, typically less than -10°F, and/or moist indoor conditions such as gym locker rooms. Available option:

- **Timed exhaust** - Cycles supply blower to melt frost with warm return air.

### Vari-Green® EC Motor

Features a soft start, overload protection, locked rotor protection, thermal protection and easy RPM adjustment through a motor potentiometer or 0-10 VDC signal.



Models ERV-10, 20, and 45 are designed for indoor and outdoor mounted commercial and institutional applications requiring 500 to 4,500 cfm of ventilation air. A key design consideration for these units is mounting location. Several duct configurations allow for floor-mounted or ceiling-hung installation. Access panels allow for easy access to the unit's enthalpy wheel, filters, motors and controls. Vari-Green® electronically commutated (EC) motors are available on ERV-10 models providing soft start, overload protection, locked rotor protection, thermal protection, and easy RPM adjustment.



Model	A	B	C	Approx. Weight (lbs.)	Airflow Range (cfm)
ERV-10	48.1	28.1	33.7	300	500 - 1,000
ERV-20	62	34.4	51	720	1,000 - 2,000
ERV-45	67	44.7	67	1100	2,200 - 4,500

All dimensions shown in inches. All weights include dampers and filters.

**Model Number Code**  
**ERV - 45 - 30H - VG**

Model Parent: ERV  
 Nominal Airflow: 45 (4,500 cfm)  
 Wheel Thickness: 30 (3 in.)  
 Vari-Green®  
 Airflow Rate: H - High, L - Low

### ERV-10, 20, 45

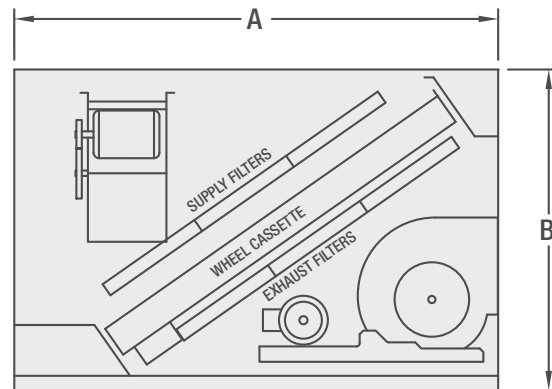
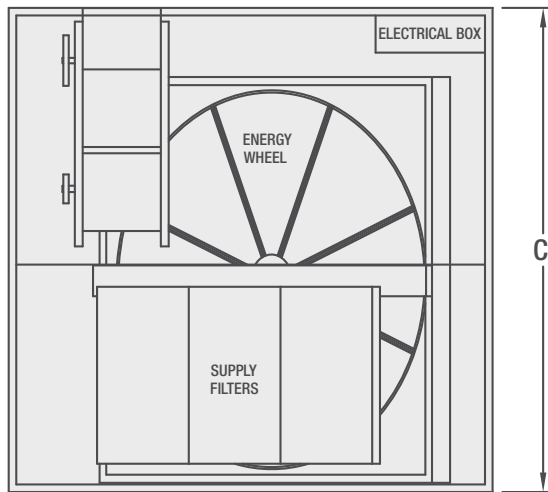



Models ERV-90 and 120 are designed for both indoor and outdoor applications requiring 4,000 to 12,000 cfm of ventilation air. The dual-wheel design provides exceptional effectiveness while retaining its ease of maintenance characteristics. Access panels allow for easy access to the unit's enthalpy wheels, filters, motors, and controls.

Model	A	B	C	D	E	Approx. Weight (lbs.)	Airflow Range (cfm)
ERV-90	124	64	84	16	25.3	3,230	4,000 - 9,000
ERV-120	146.3	77.5	96.7	18	29.3	3,700	9,000 - 12,000

All dimensions shown in inches. All weights include weatherhoods, dampers, and filters.

Available Intake/Discharge Positions				
Option	Bottom	Top	Side	End
OA Intake				X
SA Discharge	X			X
RA Intake				X
EA Discharge			X	X

## ERV-90, 120

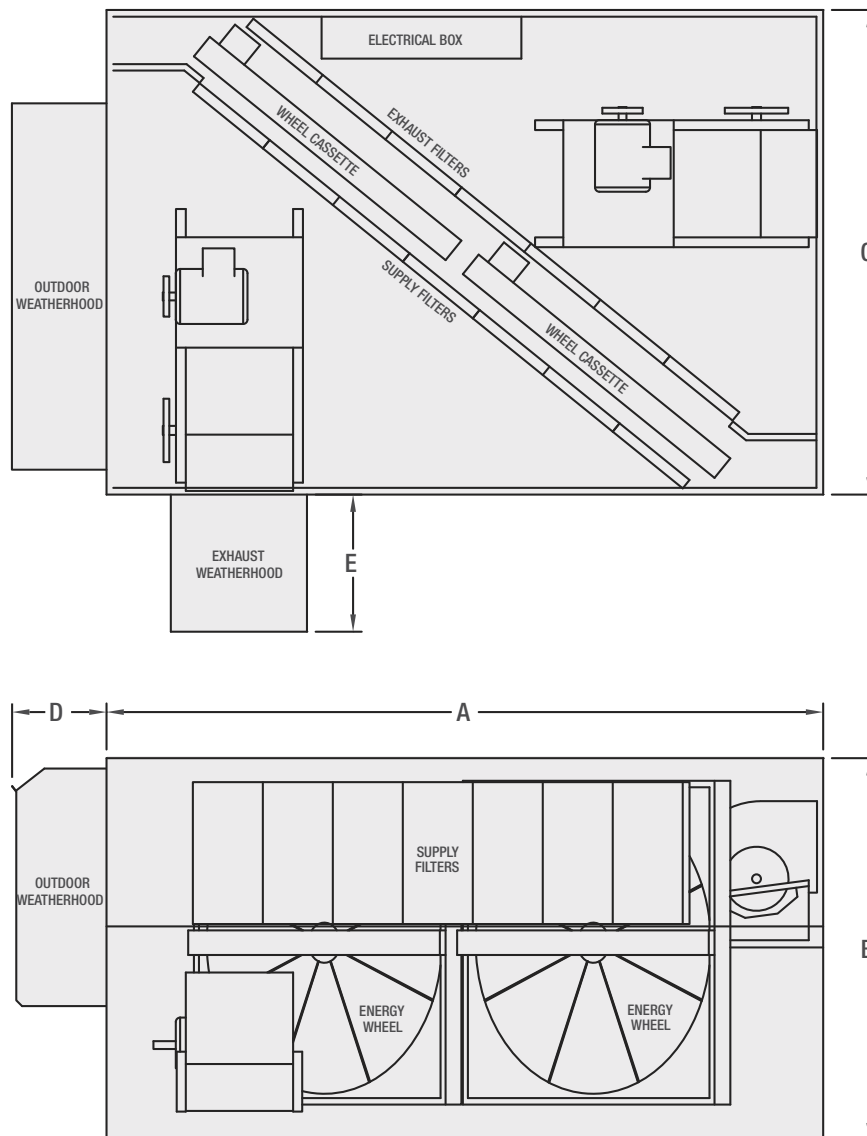

The model ERVe is designed for outdoor-mounted commercial and institutional applications requiring 1,000 to 6,000 cfm of ventilation air. The configurability of this unit allows for easy incorporation on rooftops or outdoor pad mounting scenarios. Hinged doors allow easy access to the unit's enthalpy wheel, filters, motor, and controls.



Model	A	B	C	D	E	Approx. Weight (lbs.)	Airflow Range (cfm)
ERVe-20	65.9	52.6	45.1	18	20.7	950	1,000 - 2,200
ERVe-35	68.1	62.6	53.2	22.1	17.8	1,270	2,200 - 3,400
ERVe-45	72.1	68.9	60.2	22	19.1	1,500	3,400 - 4,500
ERVe-55	83	75.4	70.2	21.7	23.5	1,960	4,500 - 6,000

All dimensions shown in inches. All weights include weatherhoods, dampers, and filters.

Available Intake/Discharge Positions				
Option	Bottom	Top	Side	End
OA Intake				X
SA Discharge	X			X
RA Intake	X			X
EA Discharge			X	

**Model Number Code**

**ERVe - 35 - 30H**

<p>Model Parent</p> <p>Nominal Airflow</p> <ul style="list-style-type: none"> <li>20 (2,000 cfm)</li> <li>35 (3,500 cfm)</li> <li>45 (4,500 cfm)</li> <li>55 (6,000 cfm)</li> </ul>	<p>Wheel Thickness</p> <ul style="list-style-type: none"> <li>15 (1.5 in.)</li> <li>30 (3 in.)</li> </ul>	<p>Airflow Rate</p> <ul style="list-style-type: none"> <li>H - High</li> <li>L - Low</li> </ul>
---	---	---

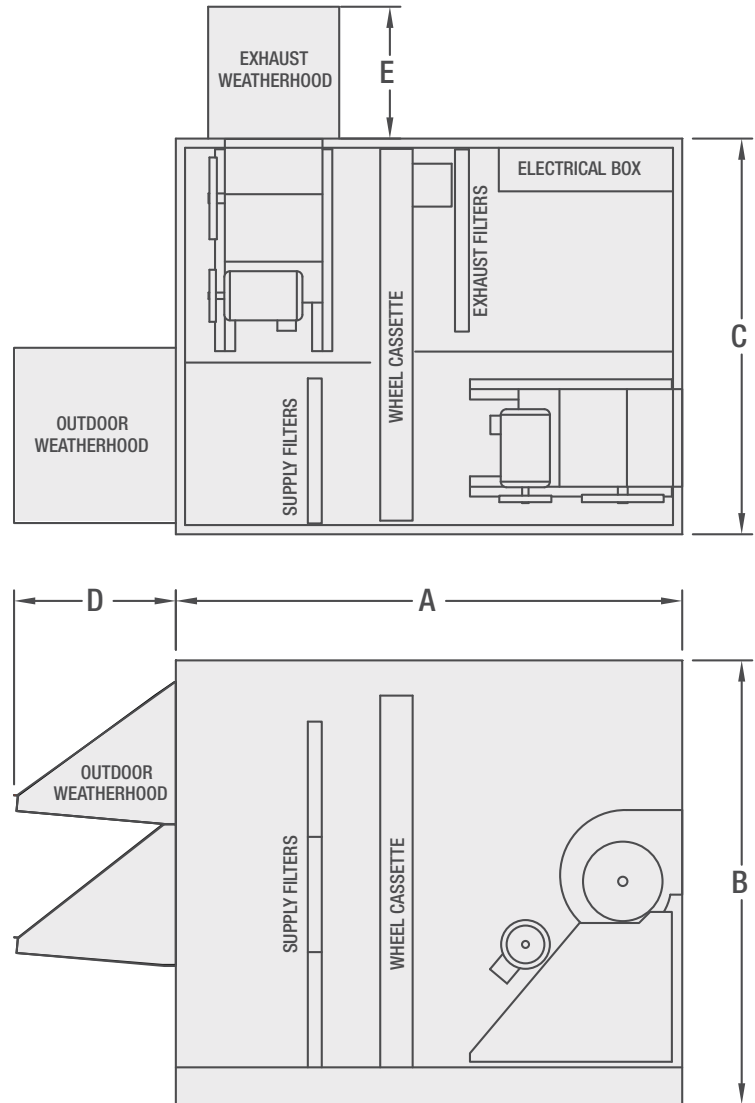

## Optional Control Sequences

### Energy Wheel Economizer Control

When the outdoor air conditions are favorable, the controller will allow the economizer operation. Available options are:

- **Stop wheel** - Energy wheel rotation will stop and outdoor air can be brought into the building unconditioned.
- **Modulate wheel** - Energy wheel speed will modulate to maintain a leaving wheel temperature of 55°F.
- **Exhaust only operation** - Unit will have the ability to receive an external signal to power off the supply fan.

### Energy Wheel Frost Control

The frost control operation prevents frost buildup on the energy wheel in climates that have cold outdoor winter temperatures, typically less than -10°F, and/or moist indoor conditions such as gym locker rooms. Available options are:

- **Timed exhaust** - Cycles supply blower to melt frost with warm return air.
- **Electric preheat** - Preheats outdoor air to avoid frosting.
- **Modulate wheel** - Reduces the wheel speed to increase the time exposed in the warm return air.

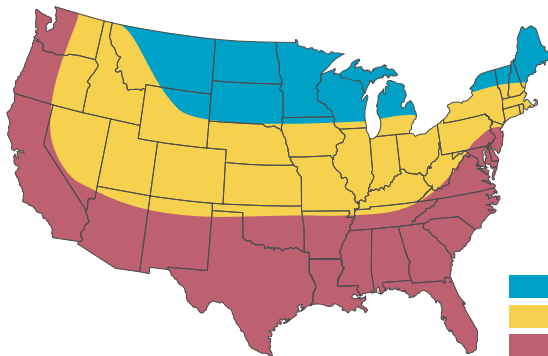

■ Preheat Frost Control Recommended\*  
■ Timed Exhaust Frost Control Recommended\*  
■ No Frost Control Needed

\*Modulating Wheel Frost Control can also be used in these areas.

## Unit Control Options

In addition to standard analog control, Greenheck is proud to offer the following direct digital control option.

### Network Interface

Available on Model ERV and Model ERVc

The network interface offers an easy-to-use, remote-mounted display which can monitor and control the unit to verify proper operation and assist with maintenance notification without the need for full microprocessor capabilities. It easily integrates to BACnet® MS/TP or IP, LonWorks® or Modbus® RTU.



### Fan Speed Control

To accommodate the system requirements, the fan speed can be adjusted with a variable frequency drive. Available options are:

- **Multi-speed** - Allows the fan to operate at three preset speeds determined by a set of input contacts.
- **Modulating** - Vary the fan speed from 50-100% based on an analog input signal.

### Demand Control Ventilation

Varies the amount of outdoor air based on occupancy. Available options are:

- **CO<sub>2</sub> Sensor** - Mounted in the unit, return air duct or in the space, this sensor determines occupancy and modulates the fan speed accordingly or it cycles the unit on and off to provide the appropriate amount of outdoor air.
- **Time clock** - A remote panel can be equipped with a 7-day programmable time clock to turn the unit on and off based on a schedule.

Frost Control Strategy Recommendations		
Winter Outside Air Design	Winter Indoor Air Design	Recommended Frost Control Strategy
≥10°F	≤50%RH	None
≥-5°F <10°F	≤35%RH	Timed Exhaust
≥10°F	≥50%RH	Electric Preheat
≥-5°F <10°F	≥35%RH	
<-5°F	Any RH	

Two operating options are available:

- **Monitor** - Allows the Building Management System (BMS) to monitor the status and functions of the unit through a factory-installed controller.
- **Monitor and control** - Allows the BMS to monitor the status and command the basic functions of the unit through a factory-installed controller.

# Additional Energy Recovery Preconditioners



## Model MiniCore

This unit will provide your building with pre-conditioned fresh outdoor air for applications ranging from 150 to 1,000 cfm. Designed for compact indoor installations, the MiniCore can mount in any orientation, providing a ventilation solution for individual spaces, such as school classrooms, dormitories, offices, nursing homes and locker rooms.



## Model ECV

Model ECV is designed for indoor and outdoor mounting for commercial and institutional applications requiring 500 to 3,750 cfm of ventilation air.



## Our Commitment

*As a result of our commitment to continuous improvement, Greenheck reserves the right to change specifications without notice.*

Product warranties can be found online at [Greenheck.com](http://Greenheck.com), either on the specific product page or in the literature section of the website at [Greenheck.com/Resources/Library/Literature](http://Greenheck.com/Resources/Library/Literature).

Greenheck P.O. Box 410 • Schofield, WI 54476-0410 • Phone (715) 359-6171 • [greenheck.com](http://greenheck.com)

Copyright © 2019 Greenheck Fan Corp. • 00.TAP.1041 R5 10-2019 SP



Prepared to Support  
Green Building Efforts